

Practicable de hoja oculta con rotura térmica de canal europeo. Ésta es una evolución de la Practic Hoja Oculta 70 RPT (HT70) y, al igual que su hermana mayor, presenta sus mismas dimensiones de superficie vista de marco; tan solo 58,8 mm. confiriendo al sistema un carácter marcadamente minimalista y, por tanto, ofreciendo una mayor superficie acristalada. Esta menor dimensión hace que las propiedades estéticas intrínsecas de un sistema de hoja oculta adquieran un mayor relieve con la HT60. Por todo esto, esta tipología de ventana es la preferida de arquitectos e interioristas. La rotura térmica se consigue mediante poliamidas de 24 mm en marco y el junquillo de coextrusión plás-

tica en hoja. Con estos materiales, se consiguen unos niveles de transmitancia térmica de marco similares a los que da una practicable de corte clásico como la Practic 45. Pero a diferencia de ésta, las dimensiones del cristal son mayores, por lo que el resultado térmico del conjunto de la ventana también es mayor y apropiado para casi todas las zonas climáticas que determina el CTE. El cerramiento se realiza mediante tres juntas, hecho que garantiza su extraordinaria estanqueidad. Sistema versátil, minimalista, térmicamente apto para casi todas las zonas climáticas y que proporciona unas máximas prestaciones. HT60 garantiza una óptima relación calidad precio.

<b>Dimensiones base:</b>	Marco:	59 mm
	Hoja:	49 mm
<b>Espesor máximo del cristal:</b>		30 mm

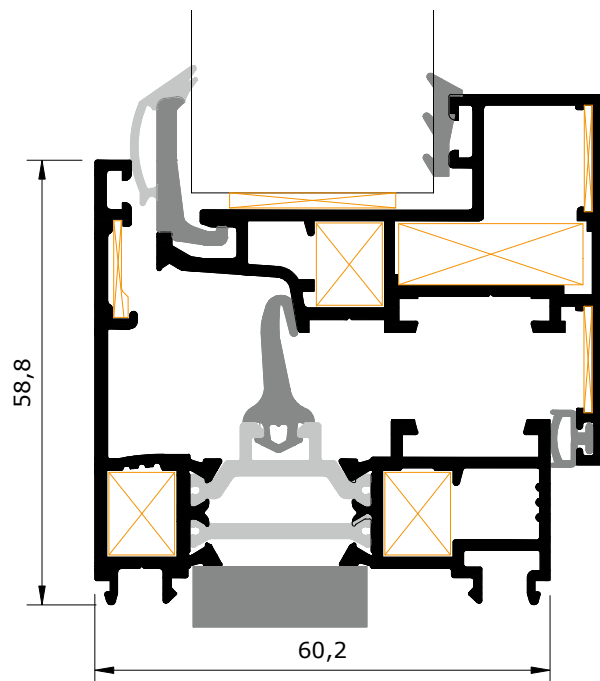

E: 1/1

**APERTURAS PRINCIPALES**

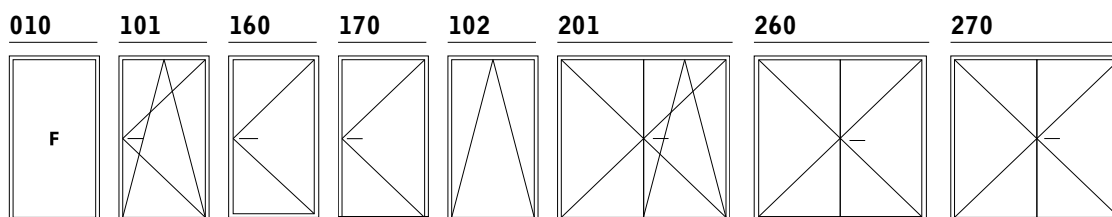

**ENSAYOS REALIZADOS AEV**

VENTANA	AIRE	AGUA	VIENTO
820 x 2100 mm 1 hoja oscilobatiente cristal 4/16/4	4	9A	C5
1600 x 2100 mm 2 hojas oscilobatiente cristal 4/16/4	4	9A	C1

**ENSAYO ACÚSTICO VENTANA**

ENSAYO ACÚSTICO VENTANA	INFORME DE ENSAYO	RESULTADO (dB)
1400 x 1500 mm 2 hojas oscilobatiente cristal 4/16/4	Interno	34
1400 x 1500 mm 2 hojas oscilobatiente cristal 3+3/16/6	Interno	37

**ENSAYOS TÉRMICOS MARCO**

ENSAYOS TÉRMICOS MARCO	INFORME DE ENSAYO	RESULTADO (W/m²K)
Nudo perimetral	Interno	3,7
Nudo central	Interno	3,7

**ENSAYOS TÉRMICOS VENTANA SEGÚN CTE**

ENSAYOS TÉRMICOS VENTANA SEGÚN CTE	RESULTADO (W/m²K)		
	4/14/4 (Ug = 2,8)	4/14/4 BE* (Ug = 1,5)	4/16 Ar/4 BE** (Ug = 1,1)
Ventana 1 hoja 820 x 2100 mm	2,99	1,97	1,66
Ventana 2 hojas 1400 x 1500 mm	3,00	2,00	1,69
Ventana 2 hojas 1600 x 2100 mm	2,97	1,91	1,59

\* Bajo emisivo

\*\* El resultado térmico ha sido obtenido colocando el Foam Isolation System en hoja y marco

**MEDIDAS VENTANA  
 CUBIERTAS POR ENSAYO**

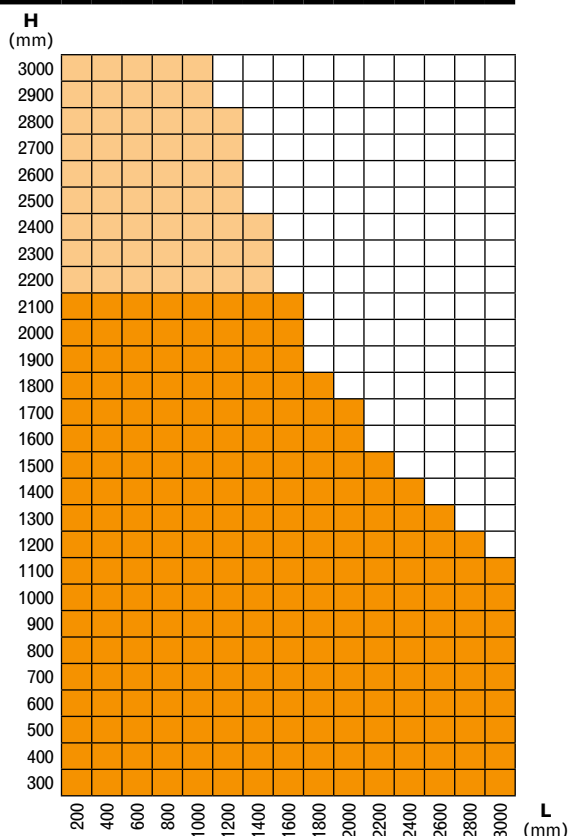

**MEDIDAS HOJA  
 NO RECOMENDABLES/NO REALIZABLES**

Peso máximo por medida de hoja\* (kg)

H (mm)	300	400	500	600	700	800	900	1000	1100	1200	1300	1400	1500	1600	1700	L (mm)
2400	110	110	110	110	110	110	110	108	105	100	95	90	86	86	76	
2300	110	110	110	110	110	110	110	108	105	100	95	90	86	86	76	
2200	110	110	110	110	110	110	110	108	105	100	95	90	86	86	76	
2100	110	110	110	110	110	110	110	108	105	99	93	88	83	83	73	
2000	110	110	110	110	110	110	110	108	104	98	92	87	82	82	71	
1900	110	110	110	110	110	110	110	109	101	95	89	84	79	68		
1800	110	110	110	110	110	110	110	109	101	94	88	83	78	67		
1700	110	110	110	110	110	110	110	109	101	94	88	83	77	66		
1600	110	110	110	110	110	110	110	108	100	93	86	81	75	64		
1500	110	110	110	110	110	110	110	106	99	92	83	78	72	61		
1400	110	110	110	110	110	110	110	106	99	90	82	77	71	60		
1300	98	110	110	110	110	110	110	106	99	90	82	76	70	59		
1200	86	98	110	110	110	110	110	105	98	89	81	75	68	57		
1100	73	86	98	110	110	110	110	100	97	87	80	68	59	46		
1000	67	79	92	110	110	110	110	91	88	79	73	60	49	26		
900	60	73	86	98	110	110	98	86	73	61	49	39	24			
800	49	61	67	76	86	79	68	65	53	44	34	22				
700	47	53	56	66	75	58	62	52	44	33	15					
600	40	45	48	56	62	46	51	40	24							
500	34	38	40	47	49	36	33									

- Cubierto ensayos permeabilidad al aire y estanqueidad al agua
- Cubierto ensayos permeabilidad al aire, estanqueidad al agua y resistencia a la carga de viento

- Medidas no recomendables
- Medidas no realizables

\* Peso máximo recomendado con herraje oscilobatiente más desfavorable

**MARCOS**

**HT60-0411** B

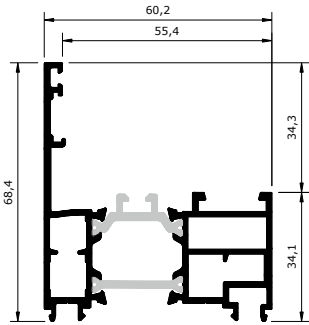

**HT60-0111** B

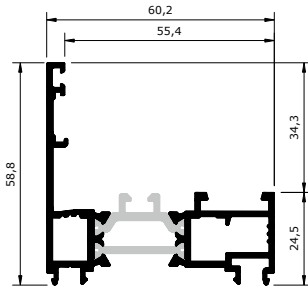

**HOJA APERTURA INTERIOR**

**HT60-1190** B

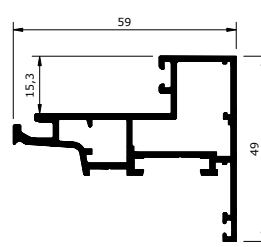

**INVERSOR**

**HT60-2390** B

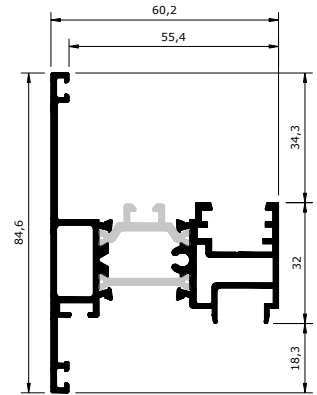

**PERFILES ESTRUCTURALES (MONTANTES Y TRAVESAÑOS)**

**HT60-3340** B

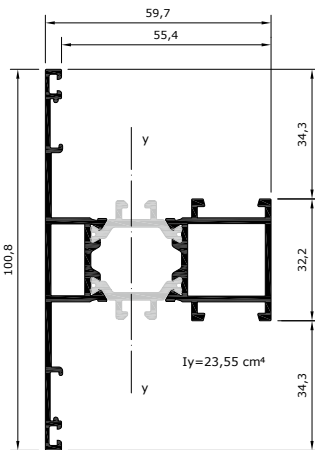

HT60  
3

**PERFILES ESTRUCTURALES DE REFUERZO UNIVERSALES**

**TP07-0279** B

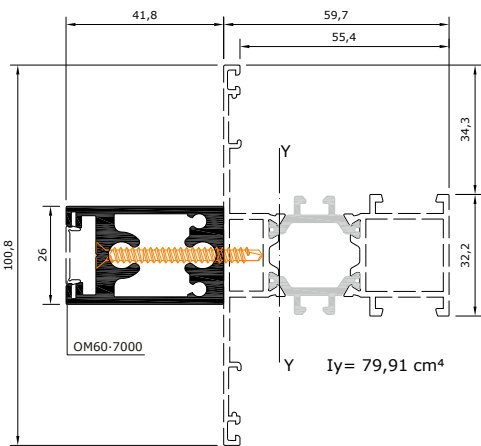

**NT10-0279** B

**NOVEDAD**

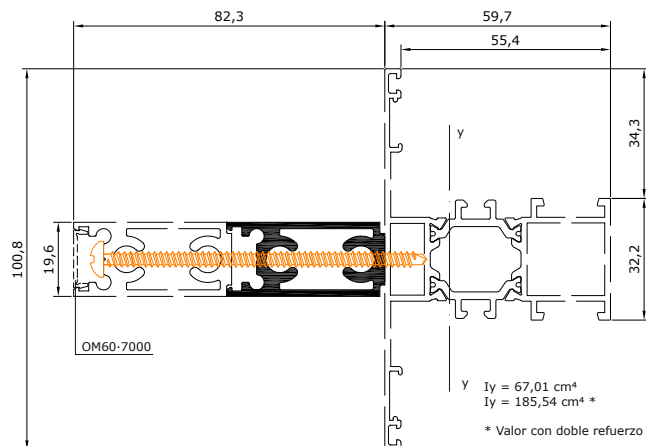

\* Valor con doble refuerzo

**JUNQUILLOS PROPIOS DEL SISTEMA**

**HT70-0534** **B**  
**NOVEDAD**

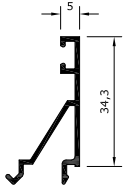

**HT70-2334** **B** **LB**

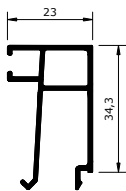

**HT70-3134** **BLR**  
 (78096)

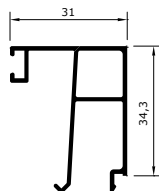

**HT70-9900**

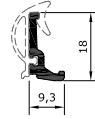

**JUNQUILLO PVC**

**HT70-PL11**  
 (PL78)

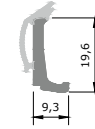

**PERFILES PORTICÓN**

**XX06-0016** **B** **LB**  
 (65916)

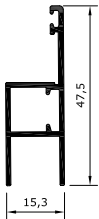

**OB30-2390** **B** **LB**

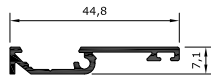

**OM60-7000** **B** **LB** **PM** **BLR** <sup>90</sup>/<sub>10</sub>  
 (2131)

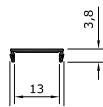

**XX09-7992** **B** **LB** **BLR**  
 (7992)

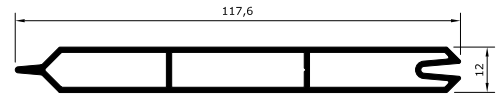

**XX09-0195** **B**  
**NOVEDAD**

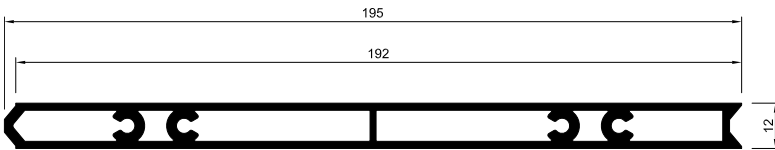

**PERFILES AIREADORES**

**GP07-3693** **B**

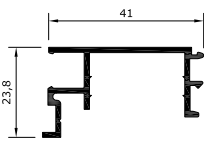

**GPM7-3693** **B** **LB**  
 mecanizado

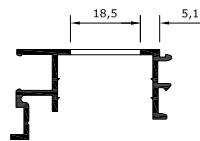

**PERFILES PARA CIERRE BAJO PUERTA**

**HT60-7098** **B**

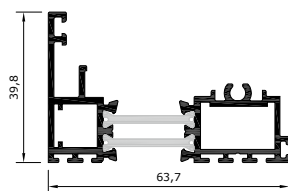

**TE07-0023** **B** **LB** **PM** **BLR** <sup>90</sup>/<sub>10</sub>  
 (62020)

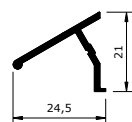

**PT54-0830** **PM**

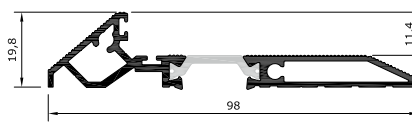

**PT45-0800** **PM**



**POSIBILIDADES DE UNIONES ENTRE SÉRIES MEDIANTE LAS DISTINTAS COMBINACIONES DE PERFILES TP01-0022, TP01-0023 Y TP06-4760**

**TP01-0022** B LB PM BLR 90 10  
(10022)

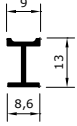

**TP01-0023** B LB PM BLR 90 10  
**NOVEDAD**

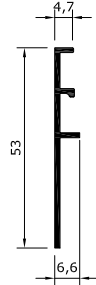

**TP06-4760** B LB PM BLR 90 10  
(64760)

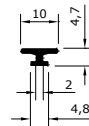

**NT71-5911 + HT60-0111**

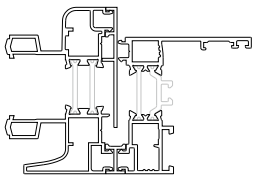

**NT71-5611 + HT60-0111**

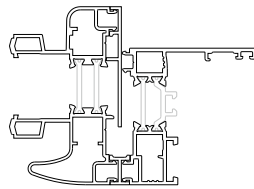

**NT71-5511 + HT60-0111**

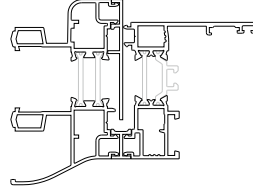

**NT71-5811 + HT60-0111**

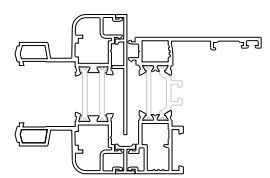

**NT71-5701 + HT60-0111**

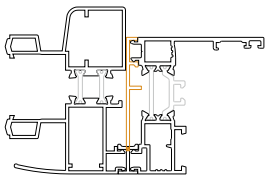

**NT95-5911 + HT60-0111**

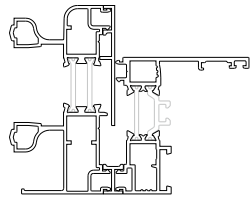

**NT95-5601 + HT60-0111**

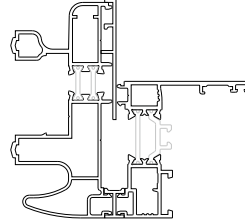

**NT95-4911 + HT60-0111**

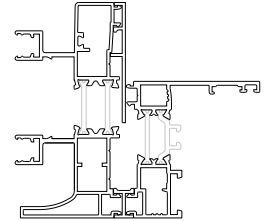

HT60  
5

**NT95-4811 + HT60-0111**

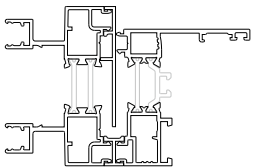

**NT95-4311 + HT60-0111**

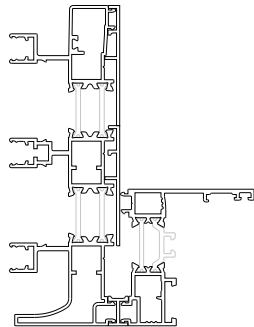

**NT95-4411 + HT60-0111**

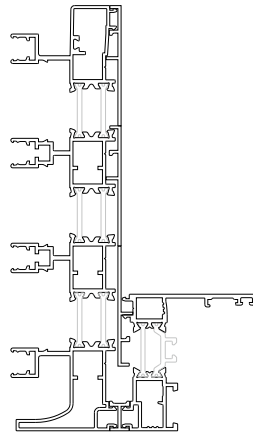

**NT10-4811 + HT60-0111**

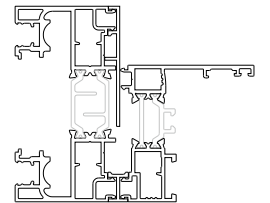



**NT10-4311 + HT60-0111**

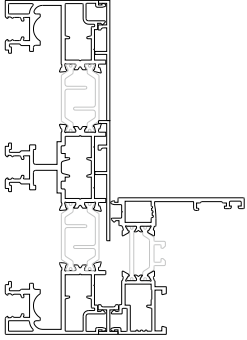

**NT71-5911 + HT60-0411**

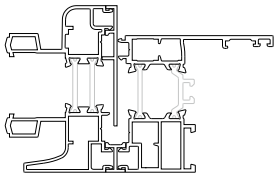

**NT71-5701 + HT60-0411**

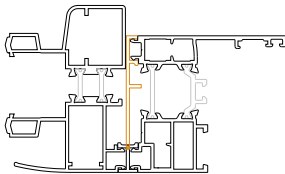

**NT95-4811 + HT60-0411**

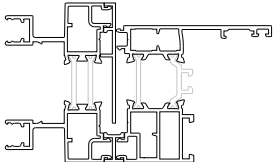

**NT10-4411 + HT60-0111**

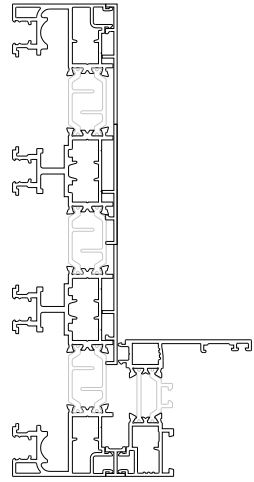

**NT71-5611 + HT60-0411**

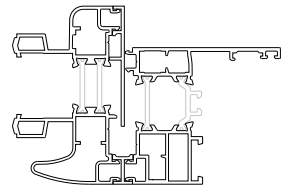

**NT95-5911 + HT60-0411**

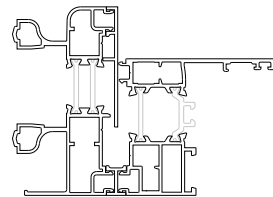

**NT95-4311 + HT60-0411**

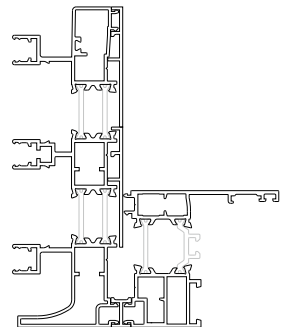

**NT11-4811 + HT60-0111**

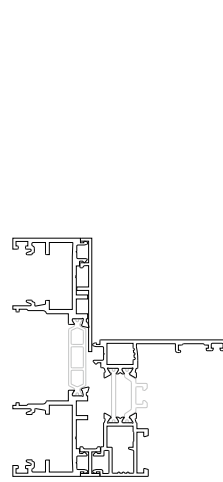

**NT71-5511 + HT60-0411**

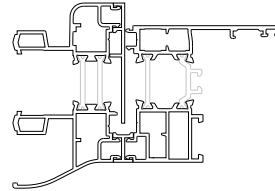

**NT95-5601 + HT60-0411**

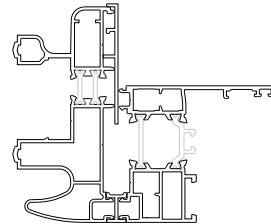

**NT95-4411 + HT60-0411**

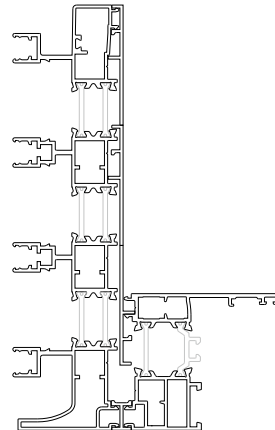

**NT11-4311 + HT60-0111**

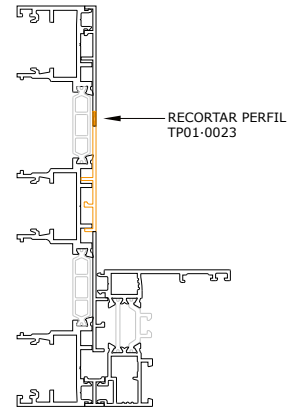

**NT71-5811 + HT60-0411**

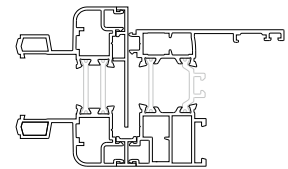

**NT95-4911 + HT60-0411**

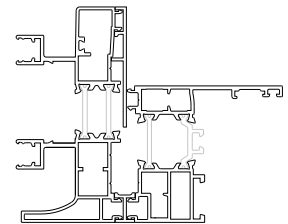

**NT10-4811 + HT60-0411**

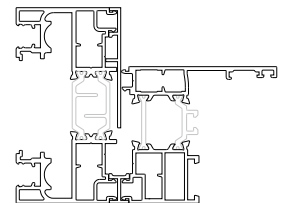

**NT10-4311 + HT60-0411**

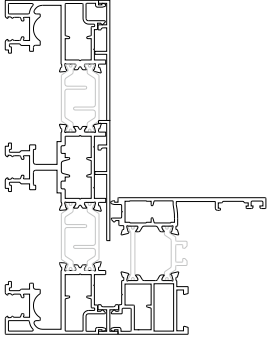

**NT10-4411 + HT60-0411**

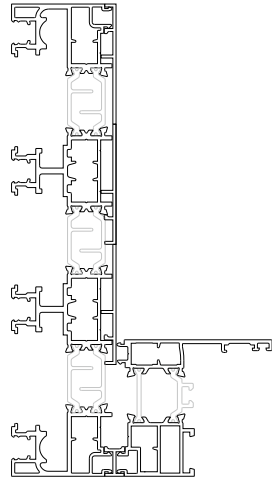

**NT11-4811 + HT60-0411**

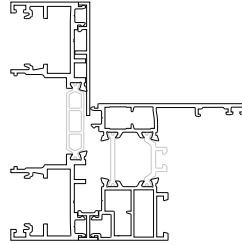

**NT11-4311 + HT60-0411**

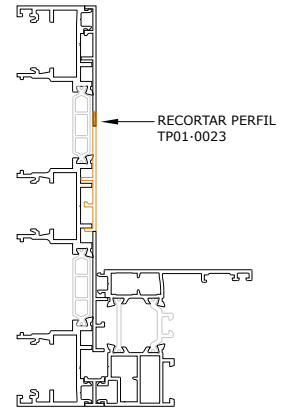

**UTILIZACIÓN DEL PERFIL TP01-0023 COMO REMATE DE MARCO**

**HT60-0111 + TP01-0023**

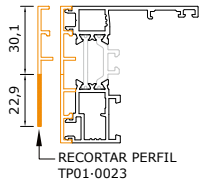



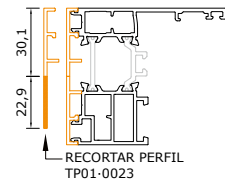





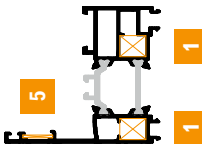









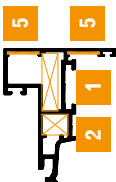





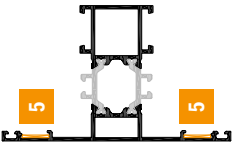

**HT60-0411 + TP01-0023**

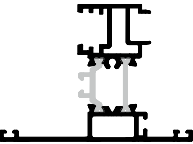

**TABLA DE ASOCIACIONES ENTRE PERFILES Y PRINCIPALES ACCESORIOS**

**ACCESORIOS RELACIONADOS**

PERFILES	ESCUADRAS Y ELEMENTOS DE TRABAJO		ESCUADRAS ALINEACIÓN		UNIONES		TAPAS INVERSORAS Y TERMINACIONES		GOMAS, JUNTAS Y FELPAS	
	ESQUEMA	REF	ESQUEMA	REF	ESQUEMA	REF	ESQUEMA	REF	ESQUEMA	REF
 HT60-0411		TPAE-6078 1		TPAE-7013 5		HA70-0392		HA70-G509		HA70-G509
		TPAE-6078 1		TPAE-7013 5		HA70-0392		PA40-G000	PA40-G000	
 HT60-1190		TPAE-6032 1		TPAE-7310 5				CPAG-G900		CPAG-G900
		TPAE-6078 2							CPAG-G907	
 HT60-3340				TPAE-7013 5		TPAE-6147		HA70-G509		HA70-G509
 HT60-2390								HA60-G419		PA40-G000
								HA60-G492		HA70-G001











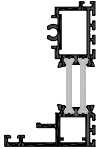









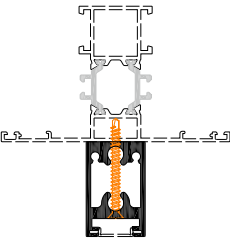

PROVISIONAL 14/12/2023

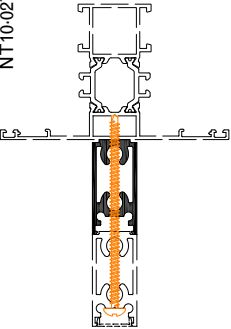
TABLA DE ASOCIACIONES ENTRE PERFILES Y PRINCIPALES ACCESORIOS

ACCESORIOS RELACIONADOS









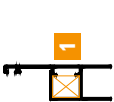

PERFILES		ESCUADRAS Y ELEMENTOS DE TRABAJO		ESCUADRAS ALINEACIÓN		UNIONES		TAPAS INVERSORAS Y TERMINACIONES		GOMAS, JUNTAS Y FELPAS	
ESQUEMA	REF	ESQUEMA	REF	ESQUEMA	REF	ESQUEMA	REF	ESQUEMA	REF	ESQUEMA	REF
	HT60-7098		HA60-6140						HA60-G419		CPAG-G906
	HT70-9900										CNAP-5009
	PT54-0830								PA45-G493		HA70-G510
	PT45-0800								PA45-G494		CPAG-G906
	TP07-0279								CNA0-0279		
	NT10-0272								NA10-0279		
	TE07-0023								CNA0-0023		



CAPÍTULO 4.1.30  
**PRACTICABLES HOJA OCULTA 60 RPT · HT60**  
**TABLA DE ASOCIACIONES ENTRE PERFILES**  
**Y PRINCIPALES ACCESORIOS**

**TABLA DE ASOCIACIONES ENTRE PERFILES Y PRINCIPALES ACCESORIOS**

**ACCESORIOS RELACIONADOS**

PERFILES	ESCUADRAS Y ELEMENTOS DE TRABAJO		ESCUADRAS ALINEACIÓN		UNIONES		TAPAS INVERSORAS Y TERMINACIONES		GOMAS, JUNTAS Y FELPAS	
	ESQUEMA	REF	ESQUEMA	REF	ESQUEMA	REF	ESQUEMA	REF	ESQUEMA	REF
	XX06-0016	 TPAE-6078 1							 OA60-G905	
	OB30-2390	 TPAE-7310 1					 OA30-G419		 CPAG-G900	
	GP07-3693						 TPA0-3693			
	GP17-3693									



PROVISIONAL 14/12/2023

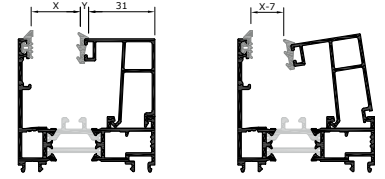
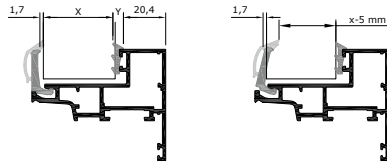

**ACRISTALAMIENTO EN HOJA HT60-1190**

X (MM)	Y (MM)						
	SIN GOMA	3	3-4	4-5	5	7	10
		CPAG-G7-0 (CF10)	CPAG-G700 (CL0K)	CPAG-G702 (CL2K)	CPAG-G704 (CL4K)	CPAG-G707 (CL7K)	CPAG-G710 (CL10K)
33							
31							
30-31							
29-30							
29							
27							
25							

**ACRISTALAMIENTO EN FIJOS CON JUNQUILLO HT70-3134**

X (MM)	Y (MM)						
	SIN GOMA	3	3-4	4-5	5	7	10
		CPAG-G7-0 (CF10)	CPAG-G700 (CL0K)	CPAG-G702 (CL2K)	CPAG-G704 (CL4K)	CPAG-G707 (CL7K)	CPAG-G710 (CL10K)
20							
18							
17-18							
16-18							
16							
14							
12							

HT60  
11

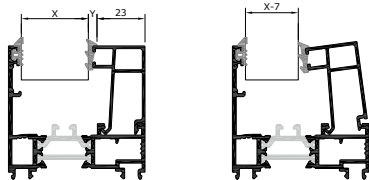

**ACRISTALAMIENTO EN FIJOS CON JUNQUILLO HT70-2334**

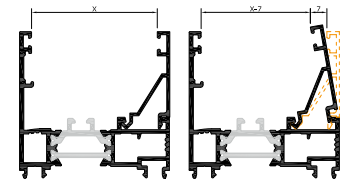

X (MM)	Y (MM)						
	SIN GOMA	3	3-4	4-5	5	7	10
		CPAG-G7-0 (CF10)	CPAG-G700 (CL0K)	CPAG-G702 (CL2K)	CPAG-G704 (CL4K)	CPAG-G707 (CL7K)	CPAG-G710 (CL10K)
28							
26							
25-26							
24-25							
24							
22							
20							



**ACRISTALAMIENTOS EN FIJOS CON JUNQUILLO HT70-0534**

X (MM)	Y (MM)						
	SIN GOMA	3	3-4	4-5	5	7	10
		CPAG-G7-0 (CF10)	CPAG-G700 (CL0K)	CPAG-G702 (CL2K)	CPAG-G704 (CL4K)	CPAG-G707 (CL7K)	CPAG-G710 (CL10K)
46							
44							
43-44							
42-44							
42							
40							
38							



### ESCUADRAS ENSAMBLE FIJAS

ESQUEMA	REF	DESCRIPCIÓN
	<b>TPAE-6078</b> (0378)	Escuadra de tiro 9 x 11 mm interior / exterior para marcos y exterior de hojas
	<b>TPAE-6032</b>	Escuadra de tiro 25 x 8 mm interior para hojas HT60-1190

### ESCUADRAS REGULABLES

	<b>TPAE-8115</b>	Escuadra regulable 9 x 11 mm
---	------------------	------------------------------





### ESCUADRAS ALINEACIÓN

	<b>TPAE-7013</b> (F2013)	Escuadra alineación FUJI
	<b>TPAE-7310</b> (8710)	Escuadra alineación hoja
	<b>TPAE-7359</b> (0359)	Escuadra alineación inox





### TAPAS ESTANQUEIDAD

	<b>HA60-G419</b>	Juego tapas inversor, canal europeo, HT60-2390
	<b>HA60-G499</b>	Juego tapas para cerramientos de una hoja acoplado a perfil HT60-7097
	<b>HA60-G492</b>	Juego tapas para cerramientos de 2 hojas acoplado a perfil HT60-7098
	<b>PA45-G493</b>	Juego tapas laterales para perfil PT54-0830
	<b>PA45-G494</b>	Juego tapas laterales para perfil PT45-0800
	<b>CNA0-0279</b>	Tapa para perfil de refuerzo TP07-0279
	<b>NA10-0279</b>	Tapa para perfil de refuerzo NT10-0279
	<b>CNA0-0023</b>	Tapa para perfil escupidor TP07-0023



### GOMAS SISTEMA

	<b>PA40-G000</b> (JCI180K)	Junta central
	<b>PA40-G009</b> (7542)	Ángulo vulcanizado para junta PA40-G000
	<b>CPAG-G900</b> (3553)	Goma burbuja interior para hoja HT60-1190
	<b>CPAG-G907</b> (E181)	Goma burbuja interior para hoja HT60-1190 para el corte continuo perimétrico







### GOMAS SISTEMA

ESQUEMA	REF	DESCRIPCIÓN
	<b>CPAG-G906</b> (3559)	Goma cuña para cerramiento de peana inferior PT54-0830
	<b>CNAP-5009</b> (F5X9)	Fepa 5 x 9 mm para HT60-7098
	<b>HA70-G510</b>	Junta exterior para junquillo de aluminio HT70-9900
	<b>HA70-G509</b>	Goma exterior vidrio 3 mm para fijos
	<b>CPAG-0823</b> (E823)	Foam Isolation System 8 x 23 mm
	<b>HA70-G001</b>	Goma lateral para inversor HT60-2390





### UNIONES

	<b>TPAE-6147</b>	Unión de 18 x 18 mm extrusión reforçada para T HT60-3340
	<b>HA60-6140</b>	Unión de 10 x 5 mm peana con marco
	<b>HA70-0393</b>	Uniones para enlazar marcos de forma continua 9x11 mm

### GOMAS CUÑA TRADICIONALES

	<b>CPAG-G7-1</b> (CF10P)	Goma de cuña interior
	<b>CPAG-G7-0</b> (CF10)	Goma de cuña interior para acristalamiento 3 mm
	<b>CPAG-G600</b>	Goma de cuña interior tradicional para acristalamiento 3/3,5 mm
	<b>CPAG-G602</b>	Goma de cuña interior tradicional para acristalamiento 4/4,5 mm
	<b>CPAG-G604</b>	Goma de cuña interior tradicional para acristalamiento 5/5,5 mm
	<b>CPAG-G607</b>	Goma de cuña interior tradicional para acristalamiento 7/7,5 mm
	<b>CPAG-G610</b>	Goma de cuña interior tradicional para acristalamiento 9/9,5 mm

### GOMAS CUÑA PRECORTADAS

	<b>CPAG-G700</b> (CL0K)	Goma de cuña interior precortada para acristalamiento B=3 mm (blanca)
	<b>CPAG-G702</b> (CL2K)	Goma de cuña interior precortada para acristalamiento B=4 mm (roja)
	<b>CPAG-G704</b> (CL4K)	Goma de cuña interior precortada para acristalamiento B=5 mm (azul)
	<b>CPAG-G707</b> (CL7K)	Goma de cuña interior precortada para acristalamiento B=7 mm (verde)
	<b>CPAG-G710</b> (CL10K)	Goma de cuña interior precortada para acristalamiento B=10 mm (amarilla)

### ACCESORIO AIREADOR

	<b>TPA0-3693</b>	Aireador por gradiente atmosférico
---	------------------	------------------------------------



**VENTANA DE UNA HOJA CON FIJO LATERAL Y CLIPAJE INNALTECH**

HT60((A2=010(0));(B2=100D(0)));1

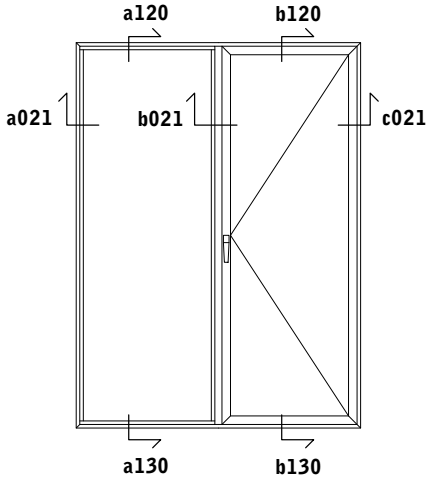

TRAVESAÑO VERTICAL  
HT60-3340: H-39

SECCIÓN VERTICAL  
b120-b130

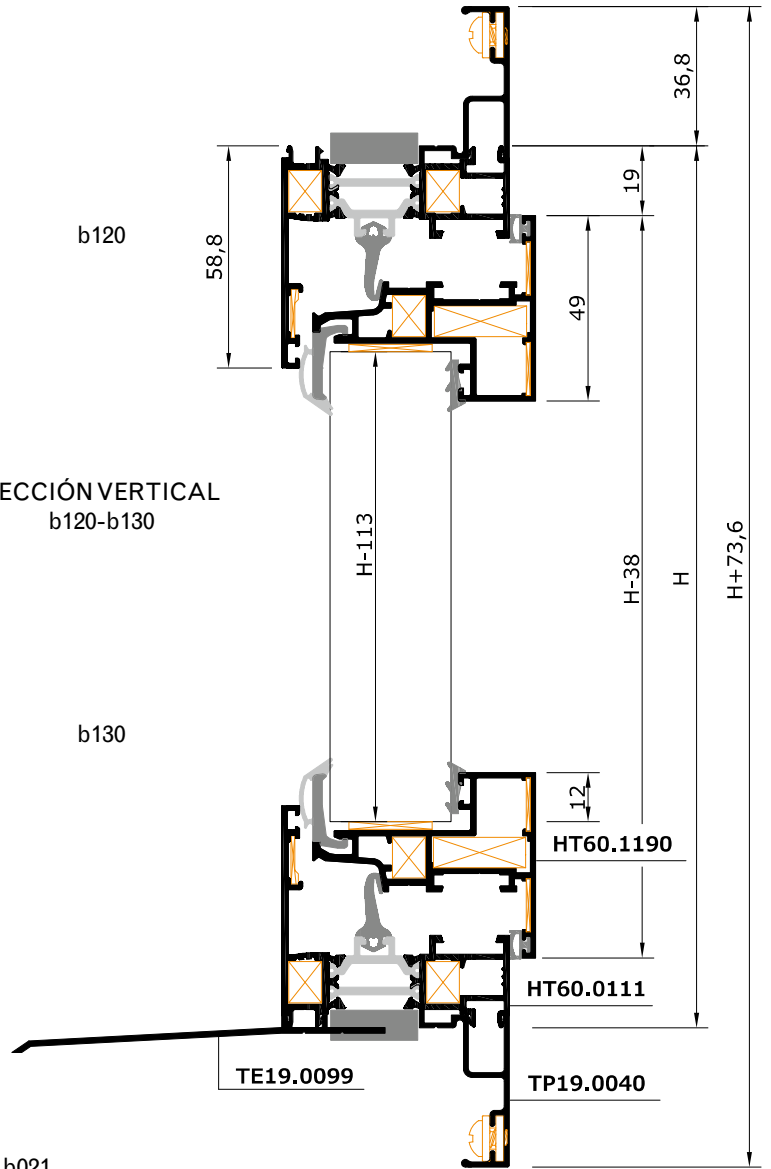

HT60  
13

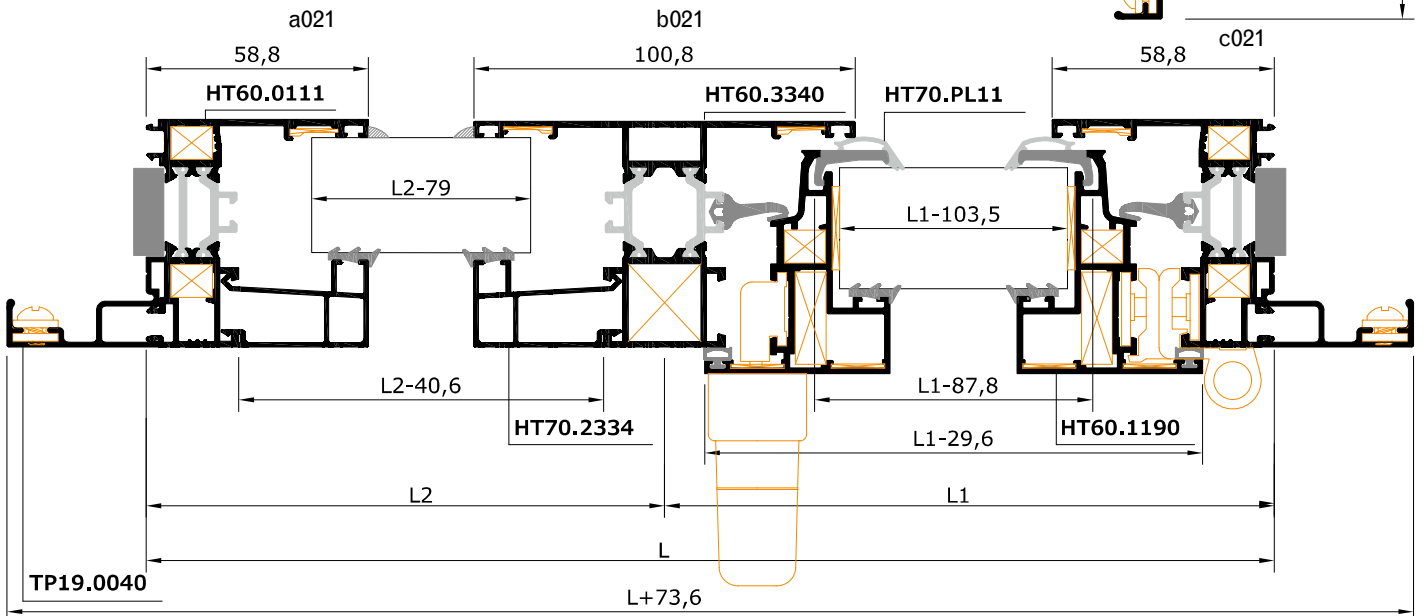

SECCIÓN HORIZONTAL a021-b021-c021

**VENTANA DE UNA HOJA CON FIJO LATERAL PEANA Y CLIPAJE INNALTECH**

HT60((A2=060(0));(B2=160D(0)));1

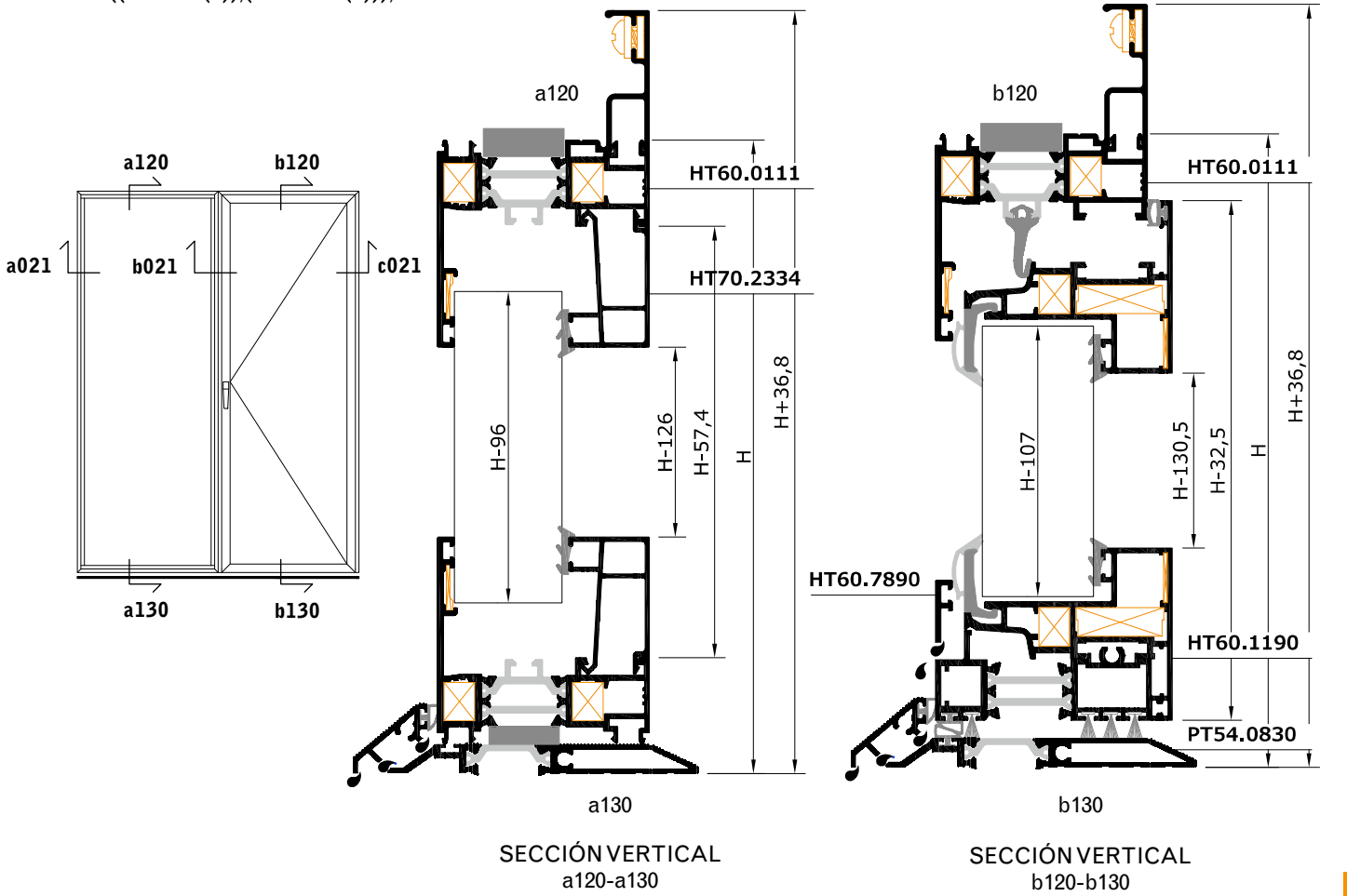

HT60  
14

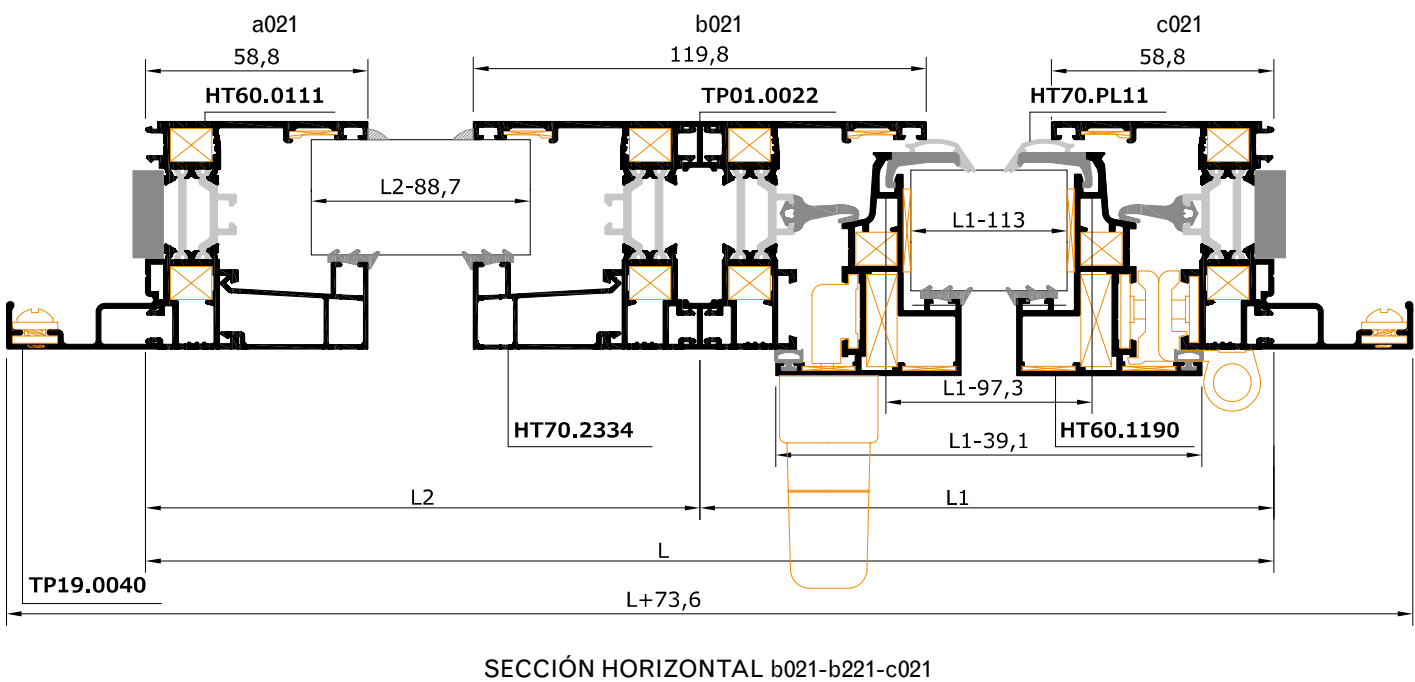



**VENTANA DE DOS HOJAS CON CLIPAJE INNALTECH Y MARCO ESTRECHO**

HT60(B2=200D(0));1

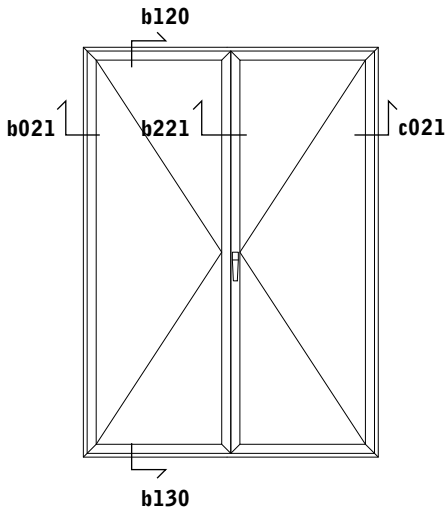

INVERSOR HT60-2390: H-128,6

SECCIÓN VERTICAL  
b120-b130

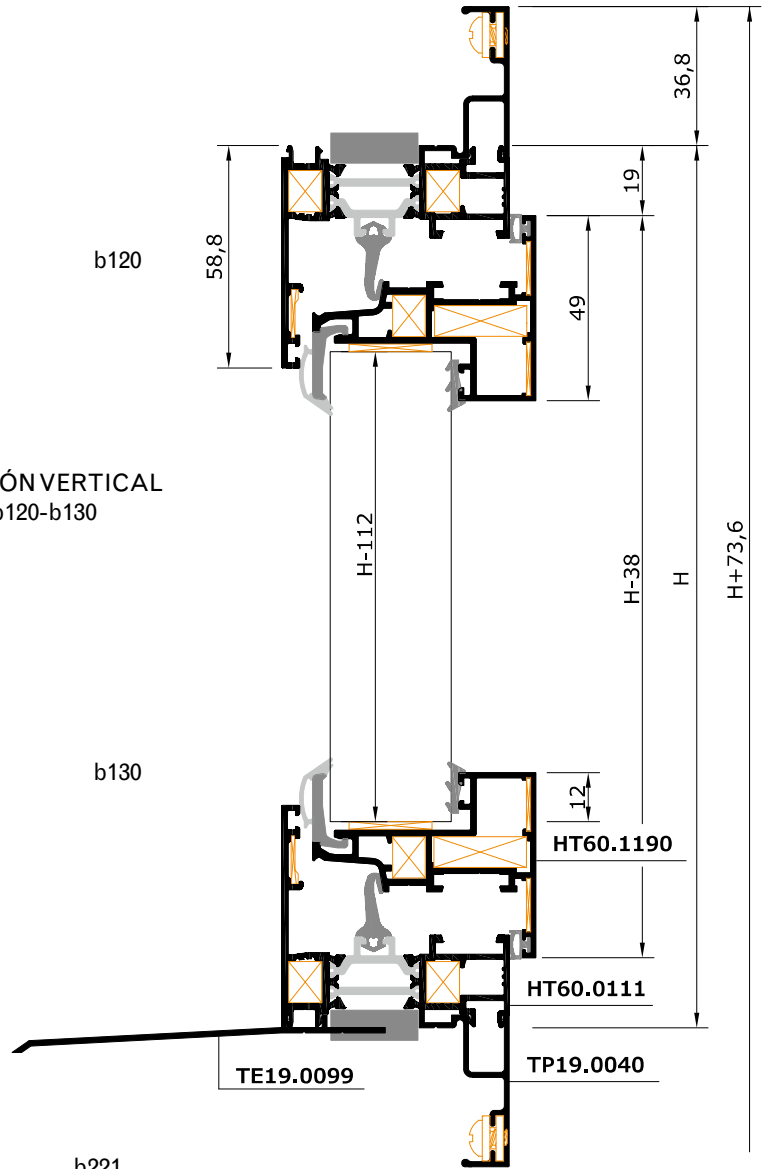

HT60  
15

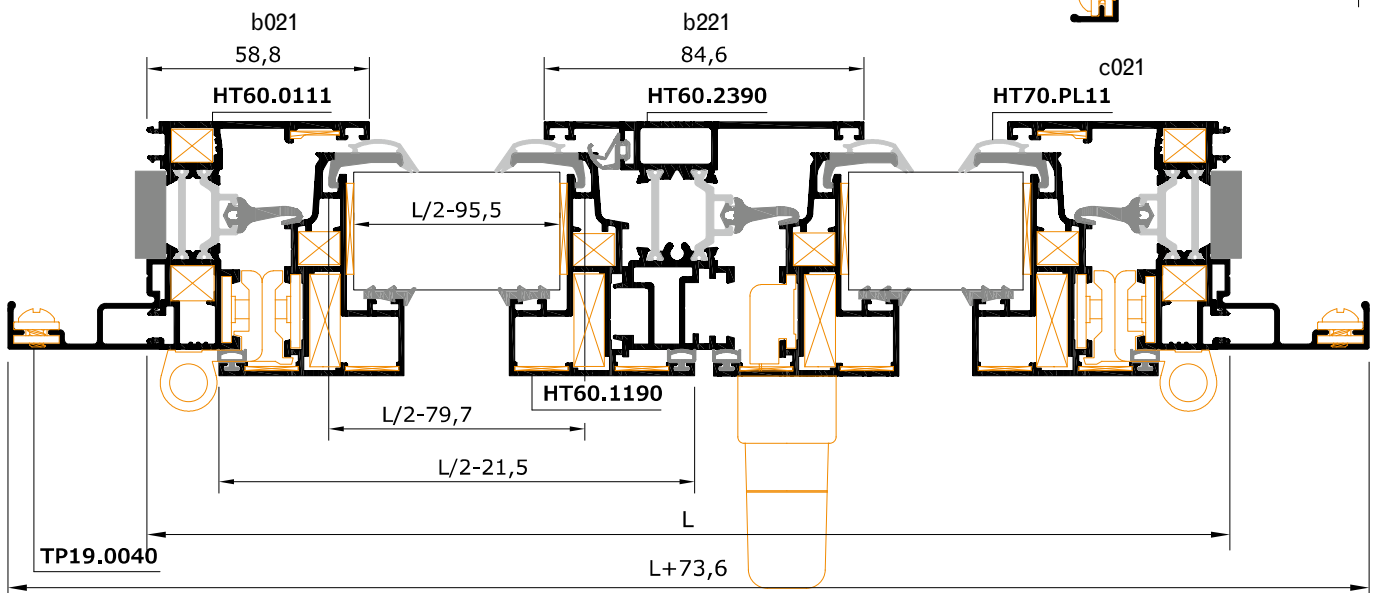

SECCIÓN HORIZONTAL b021-b221

**VENTANA DE DOS HOJAS CON CLIPAJE INNALTECH Y MARCO ANCHO**

HT60(B2=200D(0));1

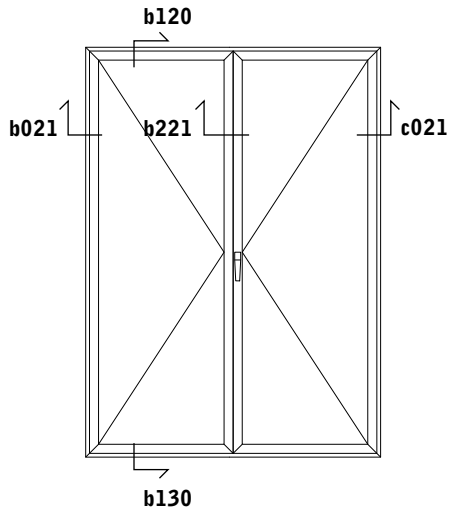

INVERSOR HT60-2390: H-147,8

SECCIÓN VERTICAL  
 b120-b130

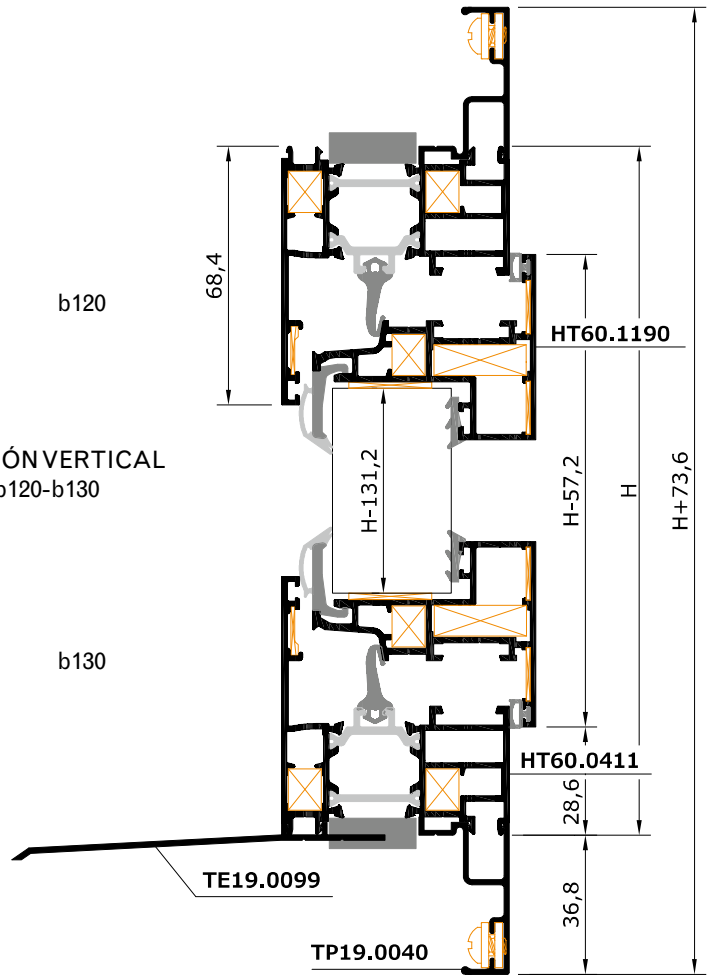

HT60  
 16

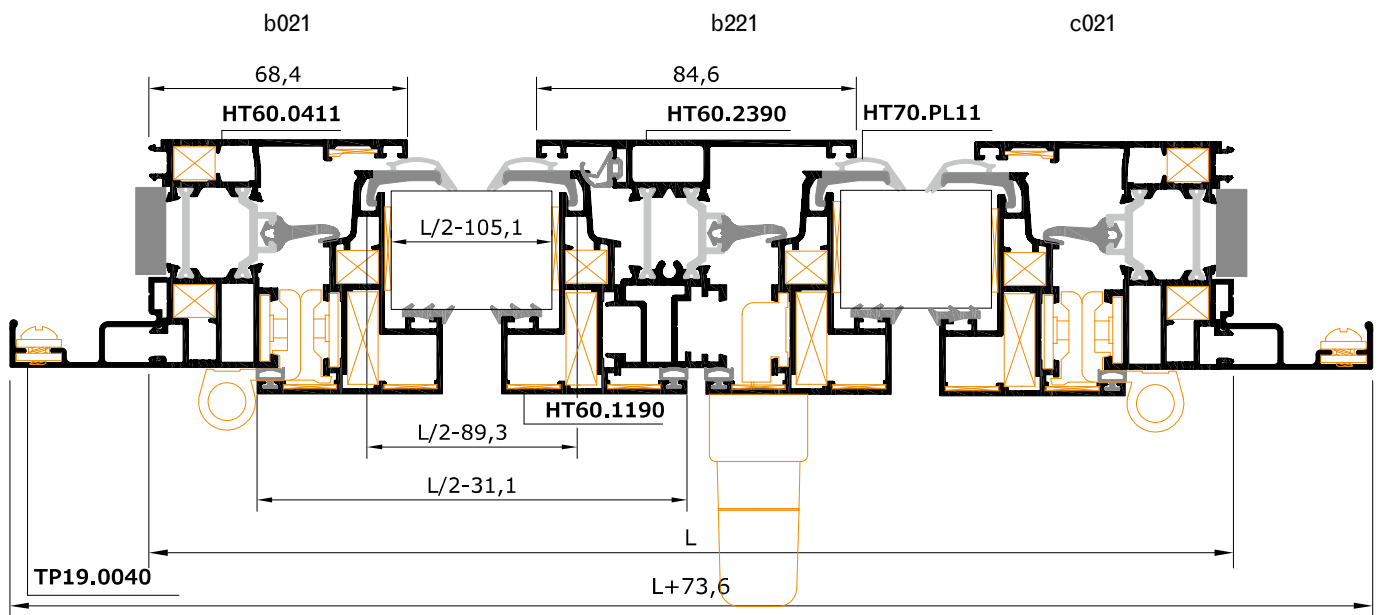

SECCIÓN HORIZONTAL b021-b221-c021